

REV	ECO	BY	DESCRIPTION	APV	DATE
A	5682	DJP	INITIAL DESIGN	RS	9/25/20
B	8361	DJP	ROTATED SLOT GEOMETRY 90° CCW	RS	2/27/24

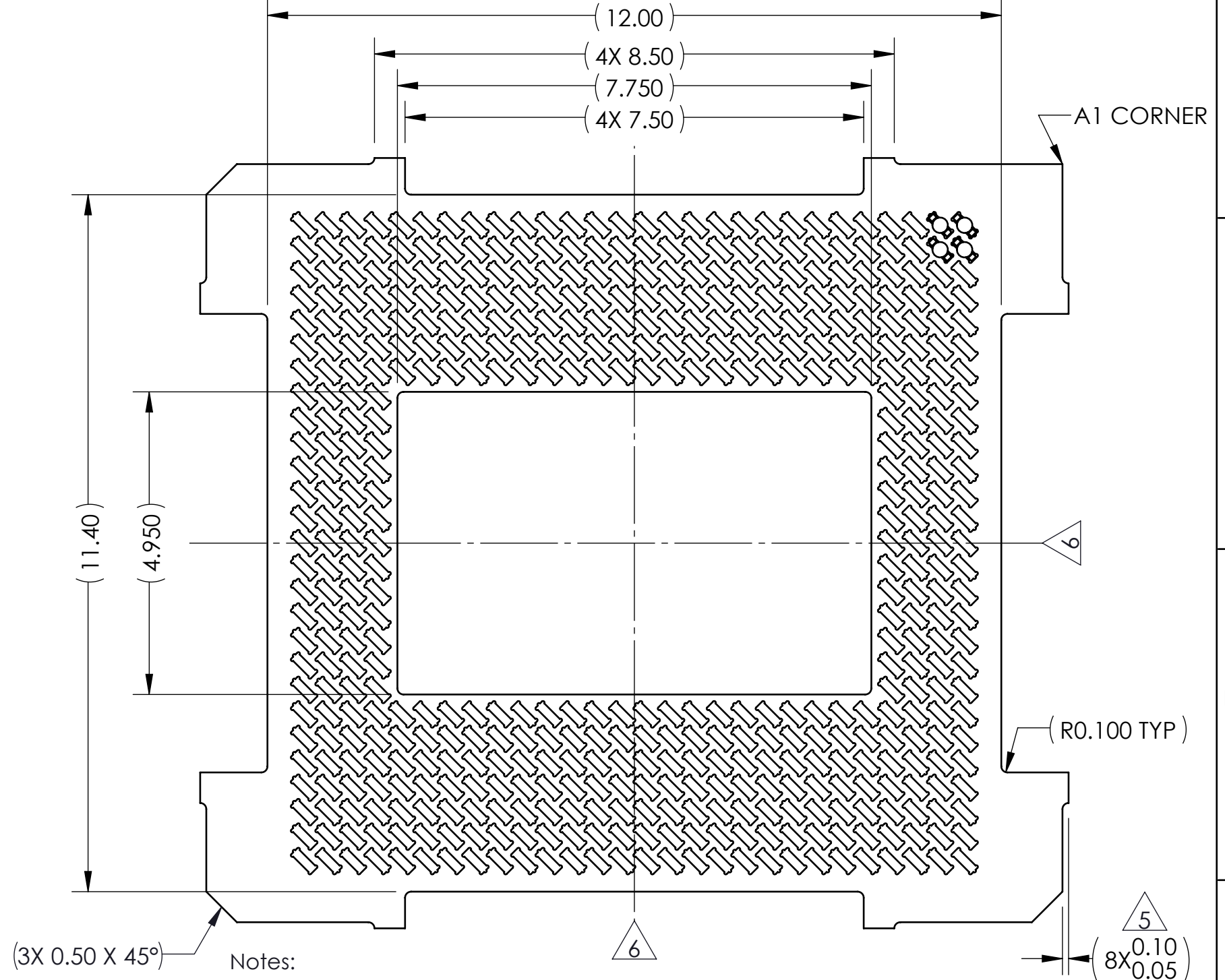

- Notes:
- 1 LOCATES CENTER OF CONTACT SLOTS.
 - 2 DATUM B AND C DETERMINED BY Ø0.315 OPENING IN CORNER SLOTS.
 - 3 UNLESS OTHERWISE NOTED, ALL FEATURES LOCATED $\ominus 0.10$ A B C.
 - 4 INCLUDES TOOLING PROTRUSIONS.
 - 5 TOOLING MARKS PERMITTED. MAXIMUM 0.10 PROTRUSION SHOWN.
 - 6 CENTERLINE OF SOCKET.
 - 7 CONTACT NUMBER: 104468-0014.
 - 8 MINIMUM SOLDER BALL EXPOSURE IS: 1/2 (Ø OF SOLDER BALL) + 0.05mm .
 - 9 HOUSING NUMBER: 107247-0109.
 - 10 SEE CUSTOMER'S P.O.D. FOR ANY MISSING FORM TOLERANCE AND/OR DIMENSIONS.
 - 11 SOCKET SHOWN FOR DEVICES THAT ARE WITHIN SPECIFIED SPECIFICATIONS.

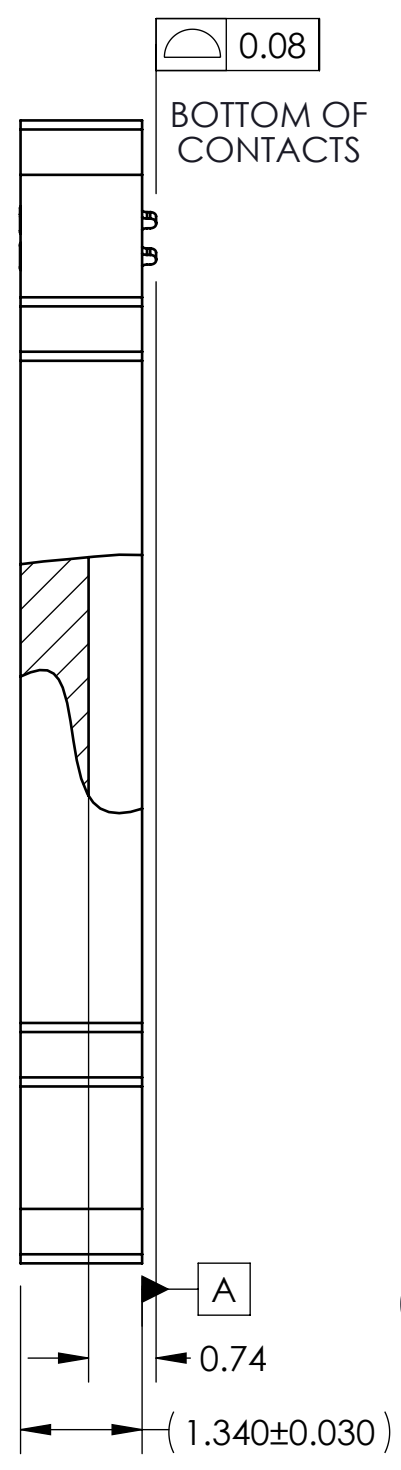
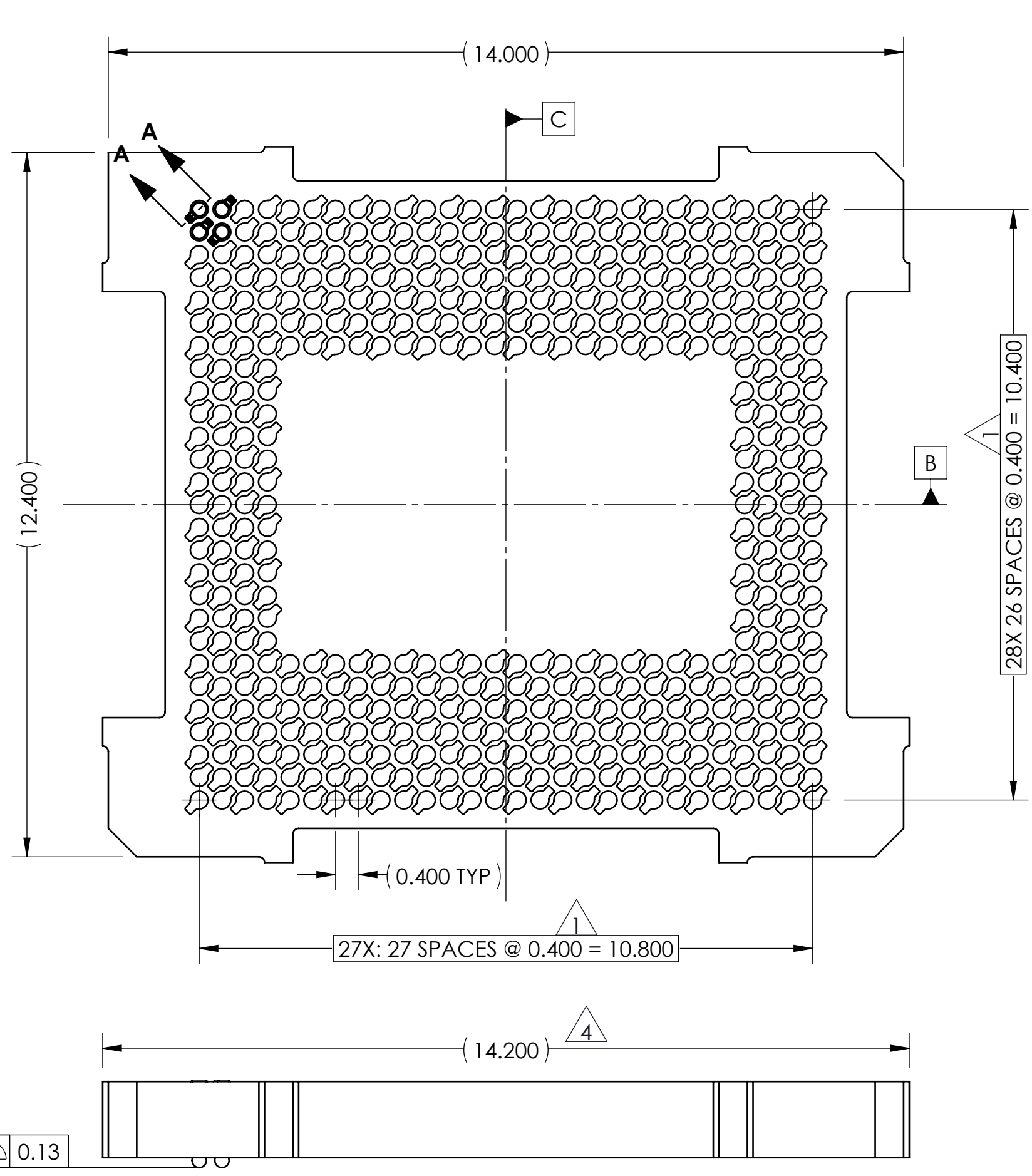
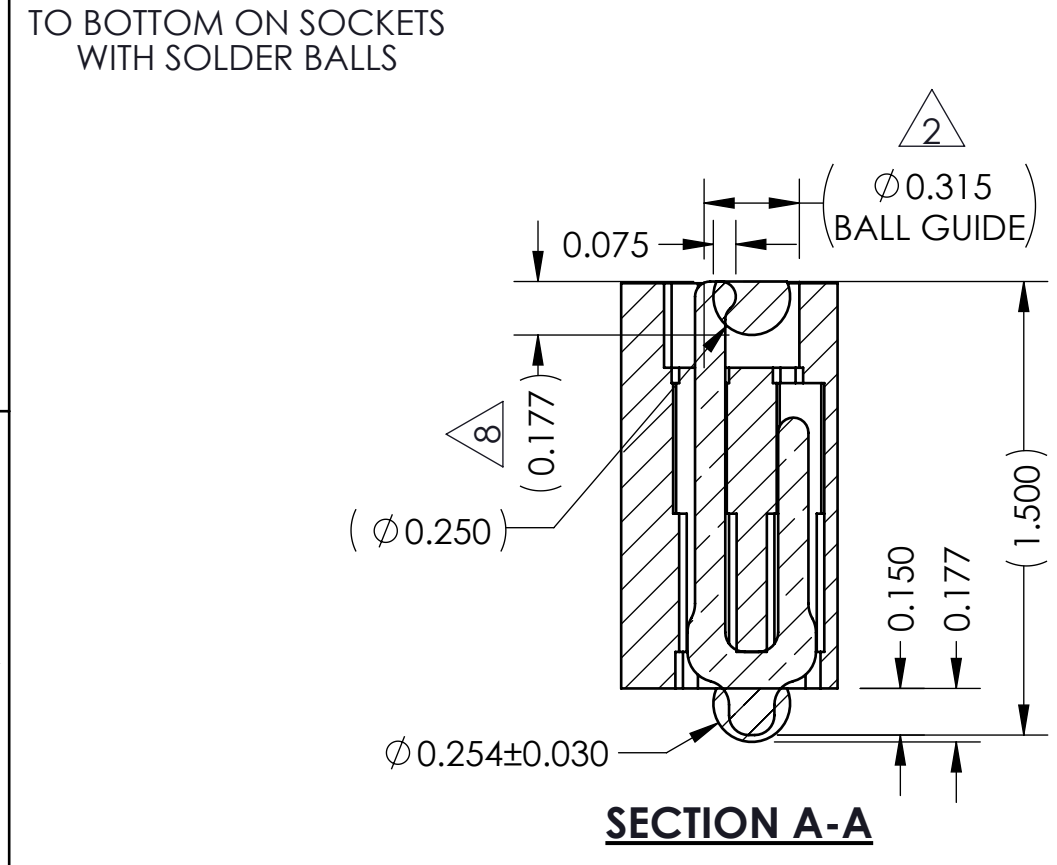

PART NUMBER	DESCRIPTION
GR1074-0001	SCKT, 496G40 14.0X12.4-0.40, PoP, EUT (EUTECTIC SOLDER BALL)
GR1074-0002	SCKT, 496G40 14.0X12.4-0.40, PoP, SAC305 (SAC305 SOLDER BALL)
GR1074-0003	SCKT, 496G40 14.0X12.4-0.40, PoP, W/O (WITHOUT SOLDER BALL)
103864-0066	PRESS DEVICE 12.0X14.0 (SOLD SEPARATELY)
104553-0508	STEN, FLEX, 496BGA 14.0X12.4-0.40 (SOLD SEPARATELY)
108639-0119	FRAME, ALIGN, GRY 14.0 X 12.4 (SOLD SEPARATELY)
105900-0004	EXTRACTION TOOL, 4 X 53 (SOLD SEPARATELY)

UNLESS OTHERWISE SPECIFIED - DIMENSIONS ARE IN MILLIMETERS - DIMS APPLY AFTER PLATING - TOLERANCES UNLESS OTHERWISE NOTED:

ANGLES ±1° DECIMALS X.X ±0.25 X.XX ±0.10 X.XXX ±0.050

THE INFORMATION CONTAINED IN THIS DRAWING IS THE SOLE PROPERTY OF IRONWOOD ELECTRONICS, INC. ANY REPRODUCTION IN PART OR WHOLE WITHOUT THE WRITTEN PERMISSION OF IRONWOOD ELECTRONICS, INC. IS PROHIBITED.

CAD GENERATED DRAWING DO NOT MANUALLY UPDATE

IRONWOOD ELECTRONICS, INC
1335 EAGANDALE CT.
EAGAN, MN 55121. 952-229-8200

SCKT, 496G40 14.0X12.4-0.40, PoP

DRAWN: DJP DATE: 9/25/20
APPVD: RS DATE: 9/25/20

LEGEND:
X NOTE CALLOUT
A REVISION CHANGE
X ITEM NUMBER

THIRD ANGLE PROJECTION

SCALE: C CAD FORMAT: SOLIDWORKS DRAWING NO: GR1074-XXXX REV: B
SHEET: 1 of 1