

REV	ECO	BY	DESCRIPTION	APV	DATE
A	6129	DJP	INITIAL DESIGN	AJN	5/4/21

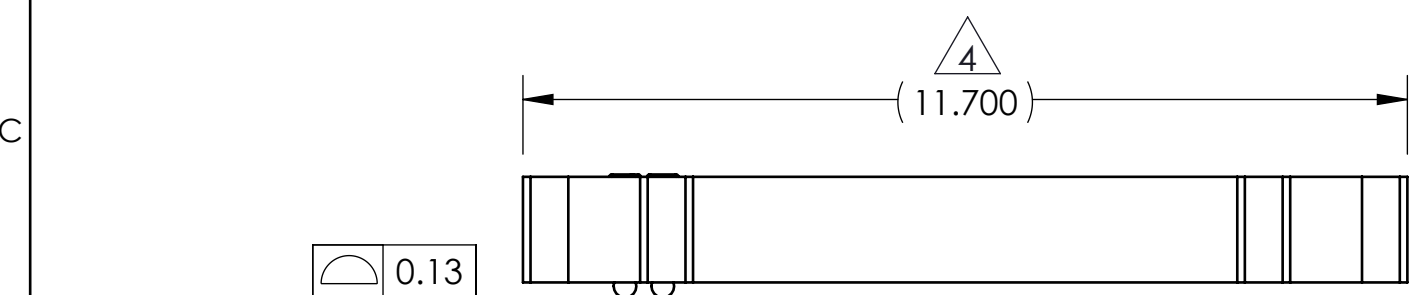

TO BOTTOM ON SOCKETS WITH SOLDER BALLS

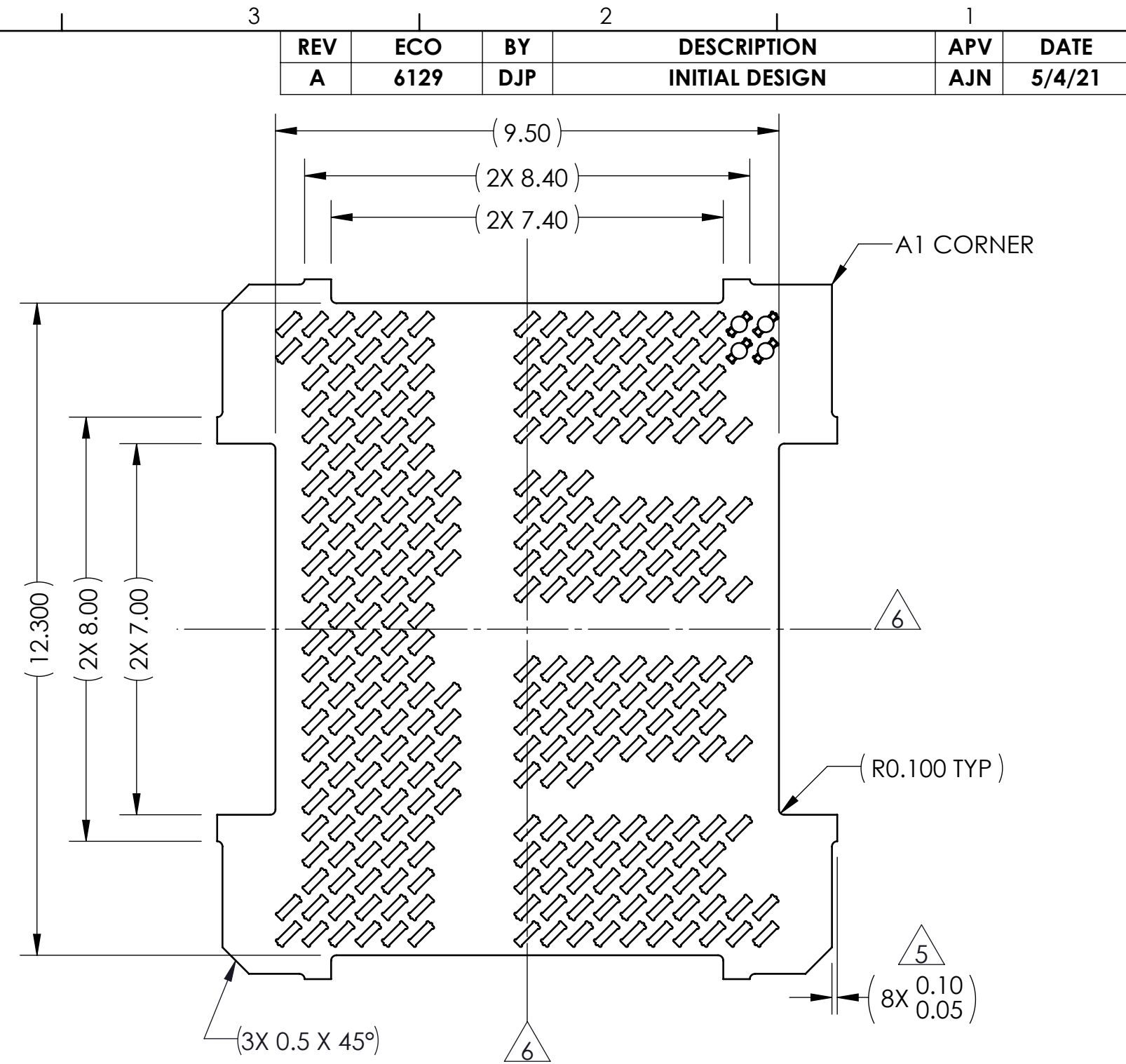
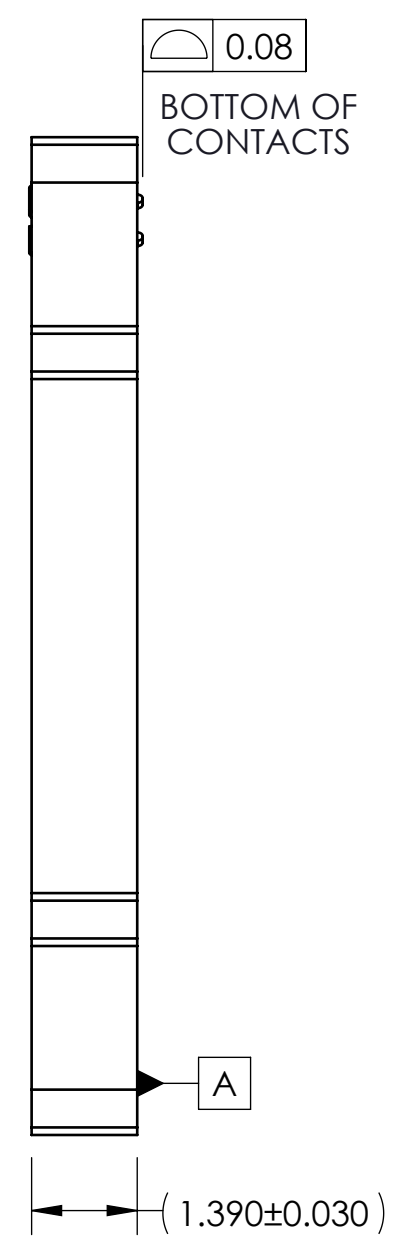
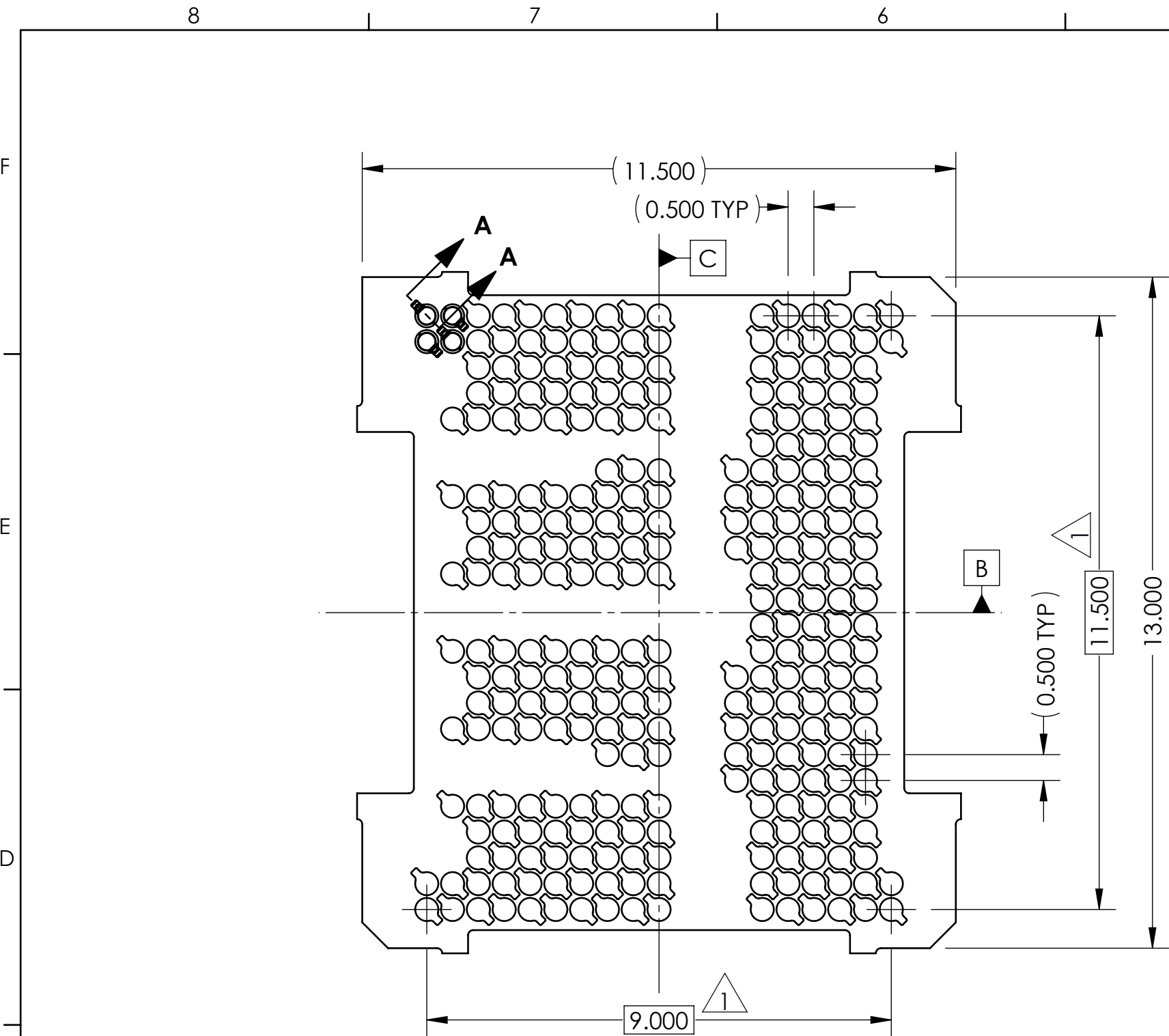
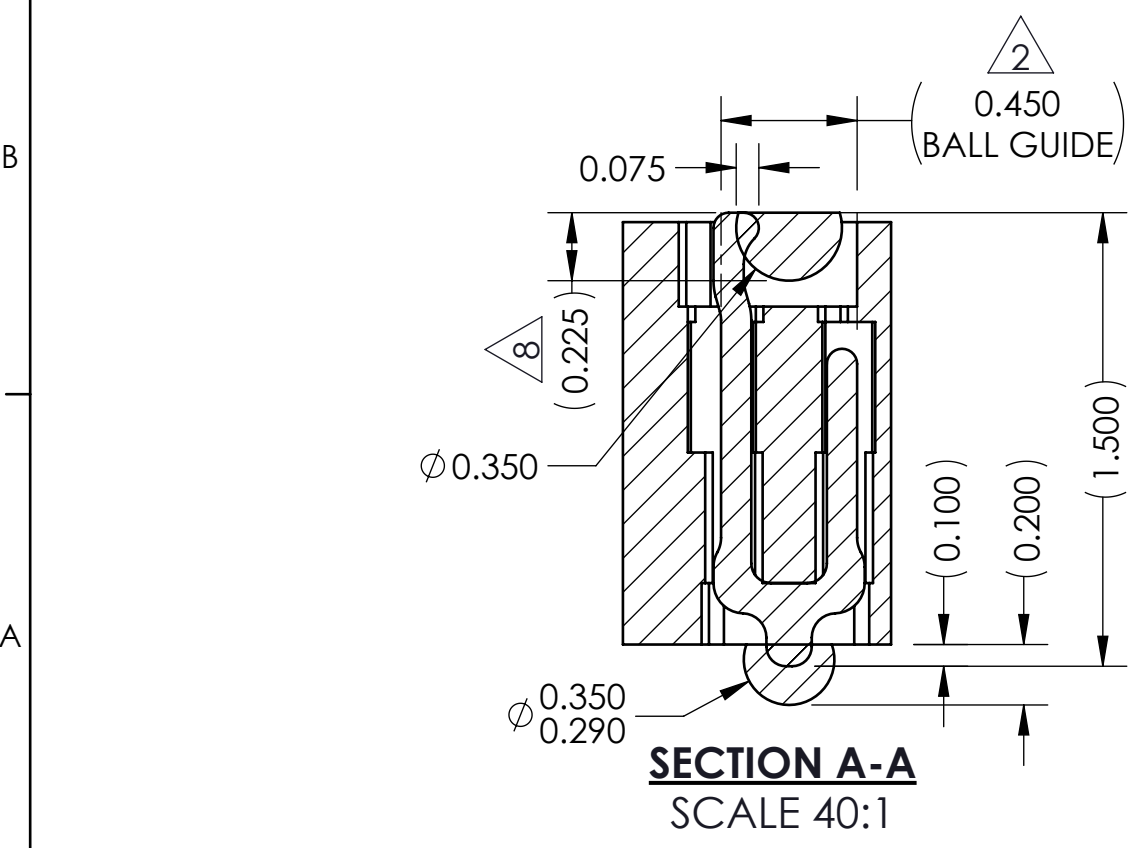

Notes:

- 1 LOCATES CENTER OF CONTACT SLOTS.
- 2 DATUM B AND C DETERMINED BY Ø0.450 OPENING IN CORNER SLOTS.
- 3 UNLESS OTHERWISE NOTED, ALL FEATURES LOCATED $\oplus 0.10$ A B C.
- 4 INCLUDES TOOLING PROTRUSIONS.
- 5 TOOLING MARKS PERMITTED. MAXIMUM 0.10 PROTRUSION SHOWN.
- 6 CENTERLINE OF SOCKET.
- 7 CONTACT NUMBER: 104468-0025.
- 8 MINIMUM SOLDER BALL EXPOSURE IS: 1/2 (Ø OF SOLDER BALL) + 0.05mm.
- 9 HOUSING NUMBER: 107271-0022
- 10 SEE CUSTOMER'S P.O.D. FOR ANY MISSING FORM TOLERANCE AND/OR DIMENSIONS.
- 11 SOCKET SHOWN FOR DEVICES THAT ARE WITHIN SPECIFIED SPECIFICATIONS.

PART NUMBER	DESCRIPTION
GR1121-0001	SCKT, 297G40 11.5X13.0-0.50, EUT (EUTECTIC SOLDER BALL)
GR1121-0002	SCKT, 297G40 11.5X13.0-0.50, SAC305 (SAC305 SOLDER BALL)
GR1121-0003	SCKT, 297G40 11.5X13.0-0.50, W/O (WITHOUT SOLDER BALL)
103864-0128	PRESS, DEV, 11.5X13.0 (SOLD SEPARATELY)
104553-0549	STEN, FLEX 297BGA 11.5X13.0-0.50 (SOLD SEPARATELY)
108639-0003	ALIGN FRAME, 11.5X13.0 (SOLD SEPARATELY)
105900-0004	EXTRACTION TOOL, 4 X 53 (SOLD SEPARATELY)

UNLESS OTHERWISE SPECIFIED - DIMENSIONS ARE IN MILLIMETERS - DIMS APPLY AFTER PLATING TOLERANCES UNLESS OTHERWISE NOTED:
 ANGLES ±1° DECIMALS X.X ±0.25 X.XX ±0.10 X.XXX ±0.050

THE INFORMATION CONTAINED IN THIS DRAWING IS THE SOLE PROPERTY OF IRONWOOD ELECTRONICS, INC. ANY REPRODUCTION IN PART OR WHOLE WITHOUT THE WRITTEN PERMISSION OF IRONWOOD ELECTRONICS, INC. IS PROHIBITED.

CAD GENERATED DRAWING DO NOT MANUALLY UPDATE

IRONWOOD ELECTRONICS, INC
1335 EAGANDALE CT.
EAGAN, MN 55121. 952-229-8200

SCKT, 297G40 11.5X13.0-0.50

DRAWING APPROVALS			GR1121-XXXX	REV. A
NAME	DATE			
DJP	5/4/21	DRAWING NO.		SHEET
AJN	5/4/21	GR1121-XXXX		
THIRD ANGLE PROJECTION		SCALE	MATERIAL	SHEET
		C SOLIDWORKS	SEE B.O.M.	1 of 1

LEGEND:
 X NOTE CALLOUT
 A REVISION CHANGE
 X ITEM NUMBER