

This Ironwood Electronics document references AMP document 114-11004, Rev 0. PLEASE REFERENCE THIS WHEN MATING AND UNMATING YOUR AMP CONNECTORS.

## **AMP** MICTOR SMT Connectors

114-11004

### 3.9. Mating and Unmating

#### **CAUTION**

*The use of uneven or off-angle forces during mating and unmating of the connectors could cause overstress and damage to the contacts and/or housings. Using the "peel-back" method of unmating one end and pulling it until the other end is unmated is permissible. Do NOT use a severe side-to-side rocking motion to unmate connectors.*

Connectors must be pushed straight in when mating and pulled straight out when unmating. A slight end-to-end motion may be used to start extraction, but it must not continue through full extraction cycle.

Miniaturization is a design feature of these connectors and the systems in which they are used. Component density, connector location, and pc board size may make it difficult to remove the connector. Two methods are recommended to facilitate removal. If unmating board-to-board connectors, the preferred method is to have one of the pc boards securely fastened and adequately supported to withstand the pulling force applied to the other pc board. The second method is to construct a tool for your system design that will produce a straight-away separation of the connectors. See Figure 14.

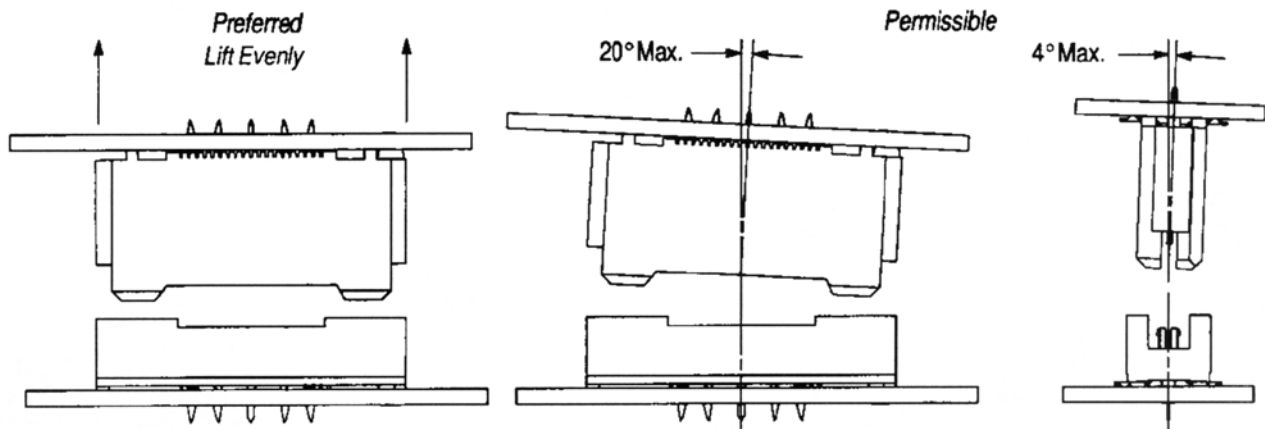

Figure 14